

DRAIN AND REFILL - REFILLING - BLEEDING : COOLING SYSTEM

1. Tooling

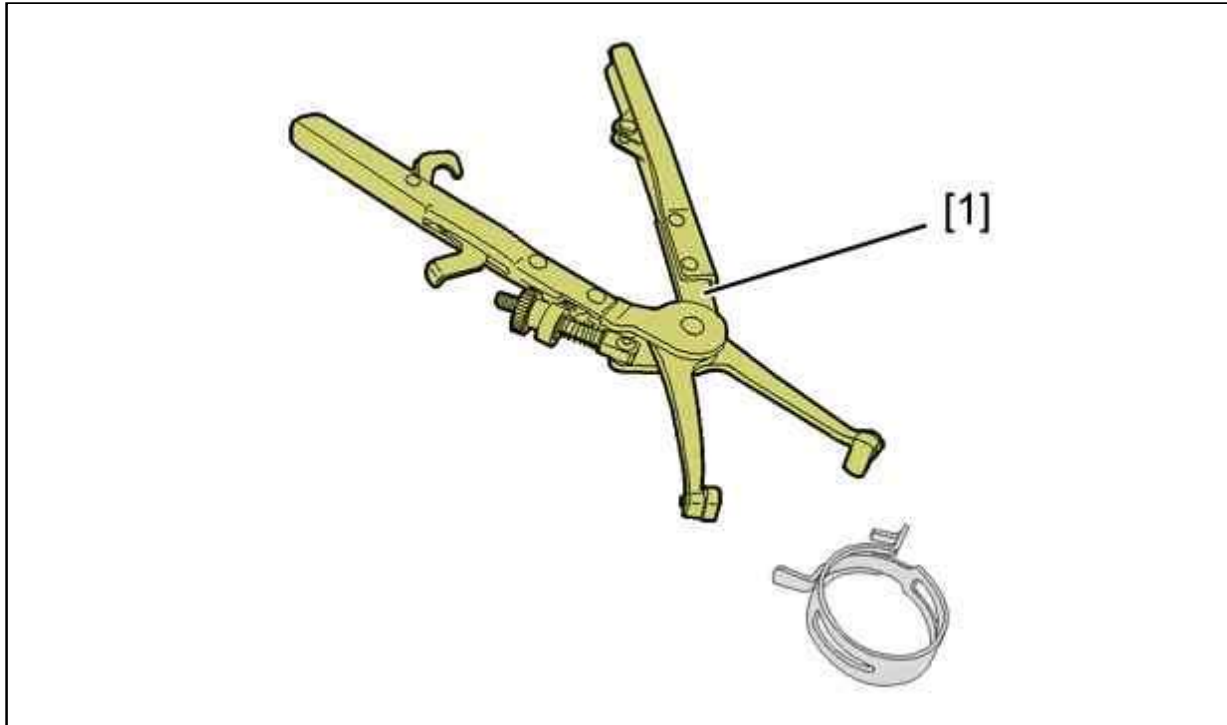

Figure : E5AP2Y2D

[1] Pliers (-).0166.

2. Drain and refill

CAUTION : The draining operation is carried out when cold.

Place the vehicle on a lift.

Raise the vehicle.

Remove : The protection shield (/) (Under the engine/gearbox assembly).

Lower the vehicle.

N.B. : Place a clean tray under the cooling radiator to permit clean draining of the system.

Carefully remove the expansion chamber cap .

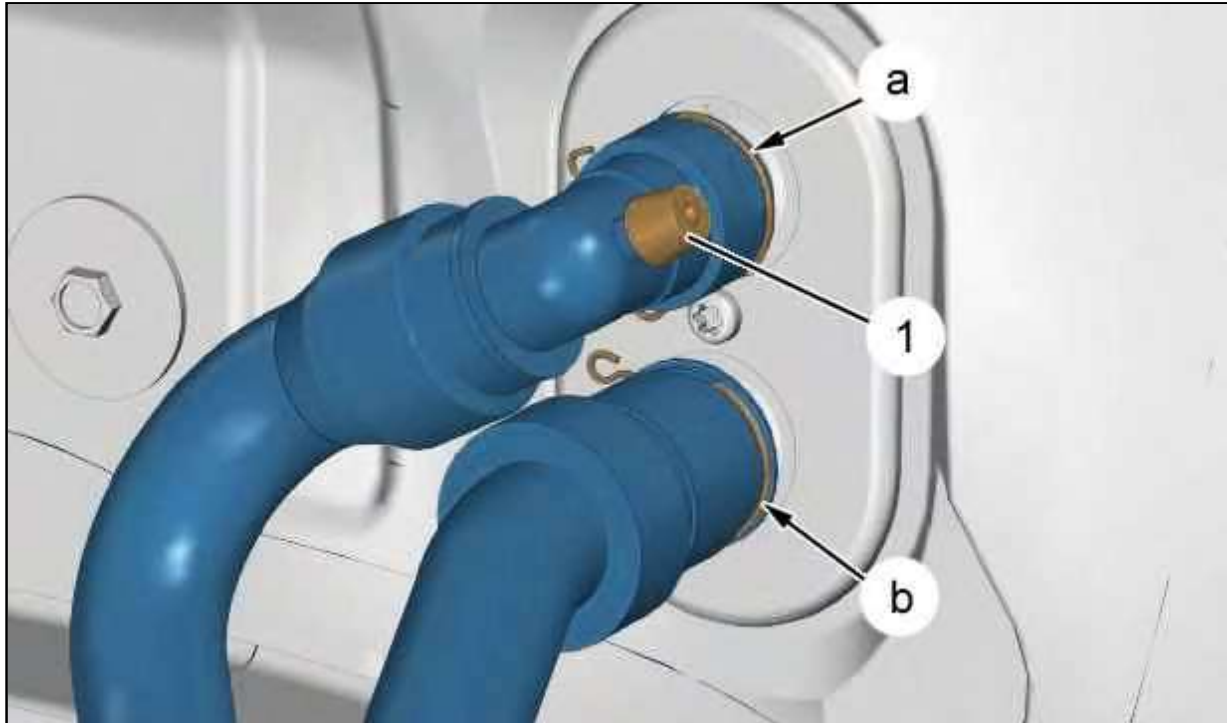

Figure : B1GP0LHD

Open the bleed screw (1) of the heat exchanger pipe .
Check that the 2 heat exchanger pipe locking clips are present (as "a", "b").

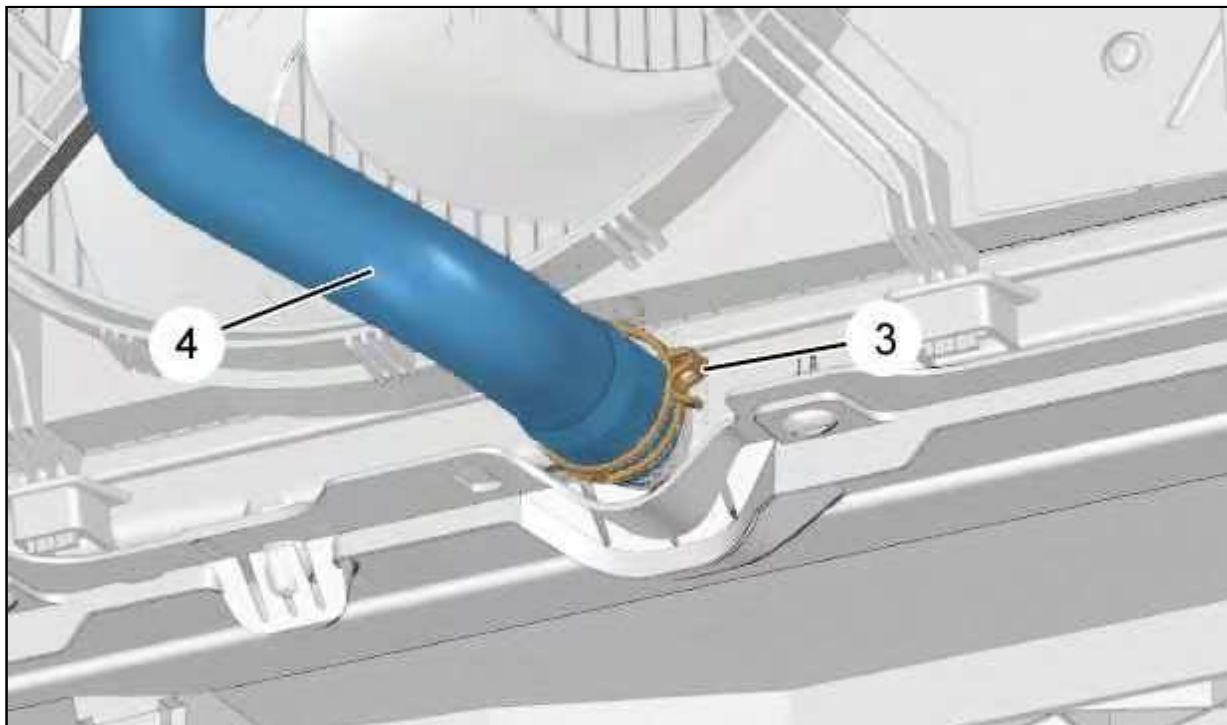

Figure : B1GP0LJD

Raise the vehicle.
Slacken the clip (3) ; Using tool [1].

The engine is drained by partially removing the cooling radiator lower pipe (4).
Allow the coolant to run out.

3. Filling and bleeding the system

ESSENTIAL : Before filling, flush the cooling system with clean water.

Reconnect the cooling radiator lower pipe (4).
Re-tighten the collar (3) ; Using tool [1].

CAUTION : Check that the lower pipe (4) on the cooling radiator is in place.

Slowly fill the cooling system with clean coolant.
Open the bleed screw (1) of the heat exchanger pipe .
Close the bleed screw (1) as soon as the liquid flows without bubbles.
Check the sealing of the cooling system.

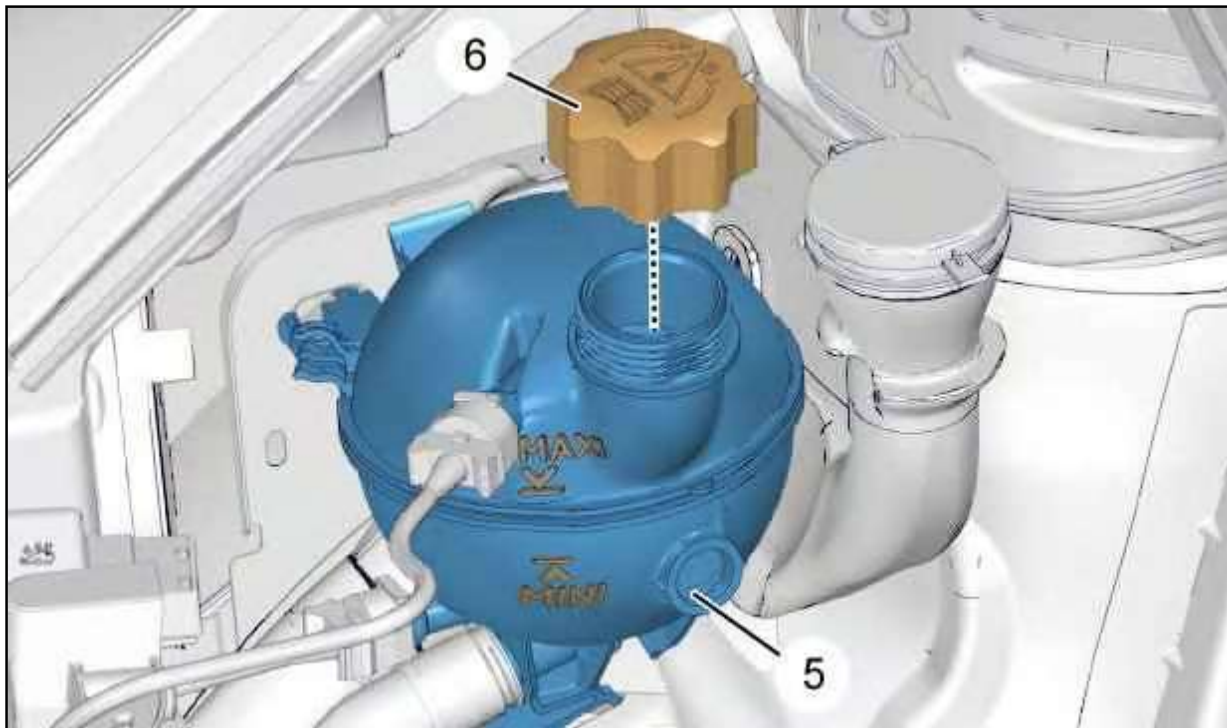

Figure : B1GP0LKD

N.B. : The expansion chamber (5) must be filled to between the max and min marks.

Refit and tighten the cap (6) On the expansion chamber (5).

Start the engine.

Maintain an engine speed of 1500 to 2000 rpm until the end of the second cooling cycle (activation then stopping of the fans, according to version).

Stop the engine.

Leave the engine to cool.

Remove the degassing tank cap (6) (5) (Carefully).

Check the coolant fluid level (Engine hot - Max mark).

Engine cold : Top up the coolant level (To the min mark) (if necessary).

Refit the shield under the engine/gearbox assembly.